

VISION 2000

The liquid turbine meters of the series **VISION 2000**® are for the exact measuring of small quantities of liquids. The actual flow as well as the already passed flow can be measured.



Model 46510-164
 Mounting tabs angled
 2 x 2,8 x 0,8 mm Ms sn



Model 46510-163
 3 flat connectors
 for electrical connector EN 60529

Principle

Flow causes the bladed rotor of the **VISION 2000**® to turn at an angular velocity directly proportional to the velocity of the fluid measured. As the blades pass beneath a magnetic pickup coil, a frequency signal is generated. Each pulse is equivalent to a discrete volume of fluid. The frequency pulse is directly proportional to the rotor angular velocity and the flow rate. The waves are readily transmitted to local or remote electrical instrumentation.

Advantages

The large number of pulses gives a good resolution. As the mass of the turbine are very small the response time is very short. It is not necessary to install a straight length of pipeline at the upstream side. The simple mechanical construction of the sensor **VISION 2000**® guarantees a long lifespan without any loss of accuracy. Pressure pulses do not affect the measuring system.

Features

- Low cost
- 6 flow ranges from 0,25 l/min to 35 l/min in the same body
- Simple construction
- Length 55 mm, weight 15 gr
- High repeatability
- Digital output
- Temperature range -20 to + 100°C
- Operating pressure 25 bar

Model number	Flow range l/min	Pulses/l	Frequency/Hz	DN	Air split/mm
46500-163-(and164-) 4F16,5	2 - 35	700	23 - 408	8	0,4
46500-163-(and164-) 4F23	1 - 25	1000	16,666 - 416	8	0,4
46500-163-(and164-) 4F44	1 - 15	2200	37 - 550	8	0,15
46510-163-(and164-) 4F44	1 - 10	3300	55 - 550	6	0,15
46500-163-(and164-) 2F66	0,5 - 7,5	4700	38 - 575	8	0,15
46510-163-(and164-) 2F66	0,5 - 5	6900	58 - 575	6	0,15

Specifications

Flow rates	See selection table
Flow medium	Liquids without particles, we recommend filtration with approx. 20 to 40 micros
Pressure rating	25 bar (200 bar bursting pressure) end connection G 3/8" or NPT 3/8"
End connection	G 3/8" or NPT 3/8"
Temperature range	-20 - +100°C
Accuracy	+/- 3% of reading
Repeatability	Better than 0,5 %
Viscosity	Up to approx. 15cSt
Pressure drop	Refer to table below
El. connection	AMP Faston 2,8/6,3 mm x 0,8 mm or 1m cable 3xAWG 24 with free cable end or connector bases with 3 flat connectors 2,8 x 0,5 fitted for electrical connector EN 60529
Power supply	5 - 24 VDC
Power consumption	Approx. 8mA
Output signal	Frequency open collector (NPN sinking)
Output current	Max. 20mA
Materials	Body: Grilamid TR55 (PA12) Turbine: PA12 Ferrit Bearings: PTFE / Graphite
Approval	All parts that are touching the medium possess the approval for cold- and warm water
Dimensions of sealing	Inside Ø 8,5 mm, outside Ø 14,5 mm thickness 2 mm, hardness approx. 70Sh A

For orders over 10'000 pieces we can respond to customers wishes regarding the connection of the medium and the electrical connections.

Pressure drop

	46500-164-4F16,5	46500-164-4F22/4F23	46500-164-4F44	46510-164-4F44	46500-164-2F66	46510-164-2F66
1 l/min	=~0	=~0	=~0	=~0	=~0	=~0
2 l/min	=~0	=~0	=~0	0,05	=~0	0,06
5 l/min	=~0	0,05	0,05	0,2	0,12	0,2
10 l/min	0,15	0,17	0,2	0,4	0,4	0,7
15 l/min	0,25	0,27	0,4			
20 l/min	0,45	0,48				
25 l/min	0,60	0,65				
30 l/min	0,92					

(delta P bar H₂O 20°C)

Dimensions

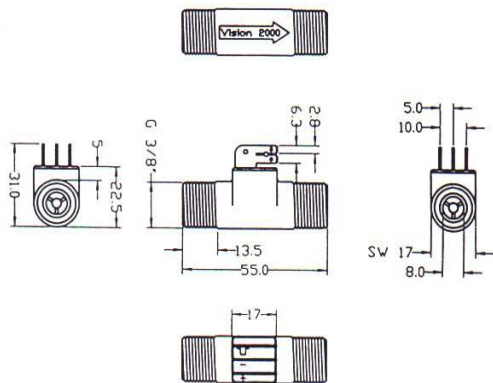

Mounting tabs angled
2 x 2,8 x 0,8 mm Ms sn

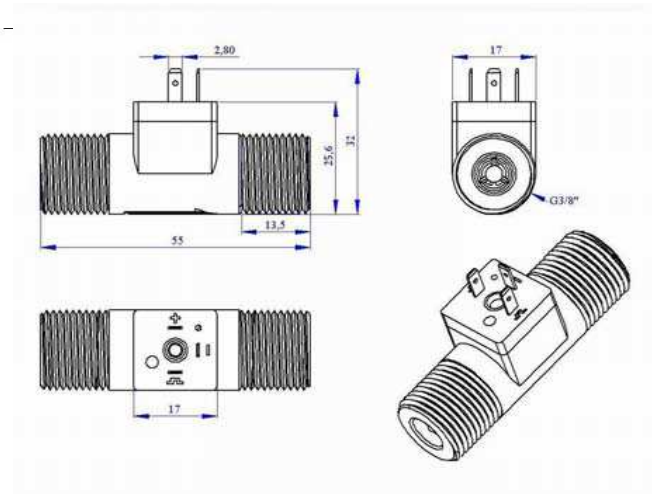

3 flat connectors
for electrical connector EN 60529

Dimensions in mm

Wiring Diagram

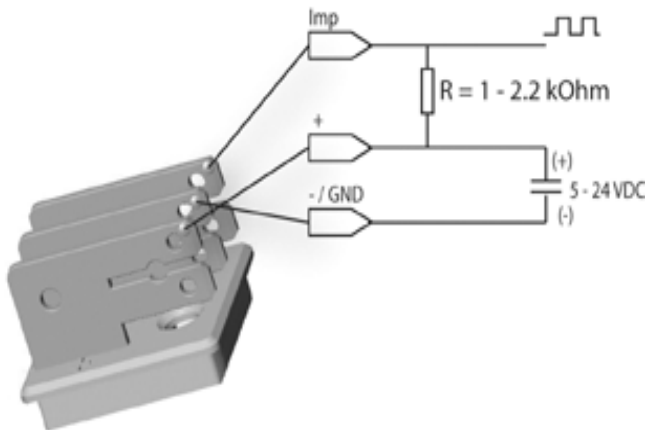

Mounting tabs angled
2 x 2,8 x 0,8 mm Ms sn

EI. Connection free cable end 3 x AWG 24 (red = plus black = minus brown = Impulse)
If you have a long feed line we recommend to install a capacitor between minus and impulse.

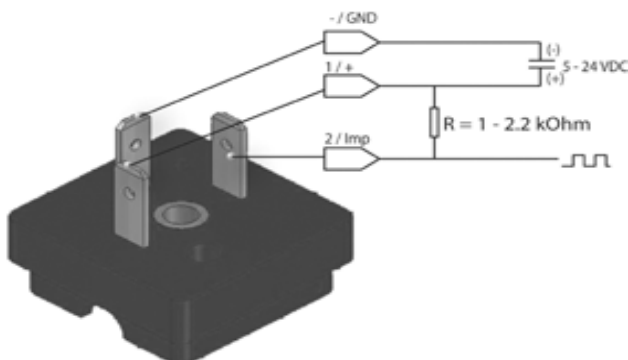

Connector bases with 3 flat connectors fitted for electrical connector EN 60529

Operating and Installation Instructions

1. Check compatibility of media with sensor material Grilamid TR55 (PA 12)
2. Filtration is mandatory if solid particles or fibres are present
3. Install sensor into properly cleaned pipeline
4. Check electrical connection according to the electrical wiring plan
5. Do not exceed the specification limits
6. The VISION 2000 ® is a volumetric measuring device, i.e. air/gas in liquid will be included in measured volume
7. Correctly installed the sensor works entirely maintenance free
8. The VISION 2000 ® is not for general public use and is to be installed and applied by trained personnel only

Disclaimer

We recommend to test the sensor for the intended purpose and to ascertain - independent of specifications - feasibility of application.